



Communications & Power Industries Receiver Protector And Control Components

RECEIVER PROTECTORS
SOLID STATE LIMITERS
PLASMA LIMITERS
SOLID STATE SWITCHES
PRESSURE WINDOWS
WAVEGUIDES
DUPLEXERS
MULTIFACTORS

Receiver Protectors and Control Components

Communications & Power Industries is the world's largest manufacturer of Receiver Protectors

CPI's Beverly Microwave Division (CPI BMD) has been designing and manufacturing receiver protector products at its Beverly, Massachusetts location continuously for over 60 years. CPI BMD is the largest and most sophisticated manufacturer of such products in the world today. Current designs span the spectrum from low-frequency coaxial limiters to complete Pre-TR Limiter, TR limiters with attenuation and phase control up to Ka-Band.

CPI BMD's products are manufactured in all transmission line types, including waveguide, coax, stripline and microstrip. Advances in computer-aided modeling techniques have made it possible for CPI BMD to achieve performance levels that would have been unheard of only a few years ago. CPI BMD's modern and extensive low- and high-power test facilities allow for complete verification of specified performance parameters.

FOR MORE RECEIVER PROTECTOR AND CONTROL COMPONENT PRODUCTS:
WWW.CPII.COM/BMD



Solid State Limiters

- Available in frequencies: L, S, C, X, Ku, Ka Bands
- High peak power handling
- Very fast recovery times
- Reliable out of band protection



Microwave Switches

- Available in frequencies: L, S, C, X, Ku, Ka Bands
- Low insertion loss
- Digital control
- Fast switching time
- SPST
- SPDT

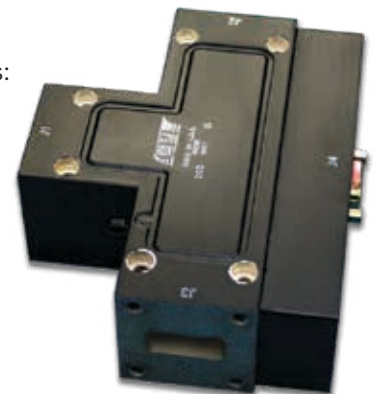

Pre-TR / Limiters

- Available in frequencies L, S, C, X, Ku, Ka Bands
- High peak power
- Very fast recovery times
- Low output leakage
- Superior broadband isolation



Pressure Windows

- Available in frequencies: L, S, C, X, Ku, Ka, W Bands
- Materials: glass, ceramic, quartz, Teflon fiberglass, Beryllium Oxide
- Low loss, low cost
- Option to add gaskets
- Option for liquid cooling



Receiver Protectors and Control Components

Communications & Power Industries is the world's largest manufacturer of Receiver Protectors



Applications:

- Missile seekers
- Airborne radar and EW
- Ground based systems
- Unmanned Aerial Vehicles (UAV)
- Naval radars
- Air traffic control
- Weather radars



TR / Limiters

- Available in frequencies: L, S, C, X, Ku, Ka Bands
- High peak power
- Longer recovery times
- Very low loss
- Passive protection
- Compact design



Pre-TR / TR / Limiters

- Available in frequencies: L, S, C, X, Ku, Ka Bands
- High peak power
- Fast recovery time
- Manages various waveforms
- Low loss protection



ASK US ABOUT INTEGRATING ADDITIONAL FUNCTIONALITY...

- Digital / Analog Attenuation
- Low Noise Amplifiers (LNA)
- Absorptive Limiters
- Couplers
- High Power Circulators
- Filters
- Noise Sources

Receiver Protector and Control Components

Radar Block Diagram

Historically, radar system designers selected various components from different suppliers without the ability to accommodate how they interact. CPI BMD has a successful history of providing additional functionality to receiver protectors, by integrating passive and active components into a single, Integrated Microwave Assembly (IMA).

CPI BMD produces a compact, more efficient integrated component, by optimizing performance, reducing development costs and ultimately, providing increased functionality to the end product.

This Radar Block Diagram depicts the various building blocks of a typical radar system that CPI BMD is capable of integrating to fit your design needs.

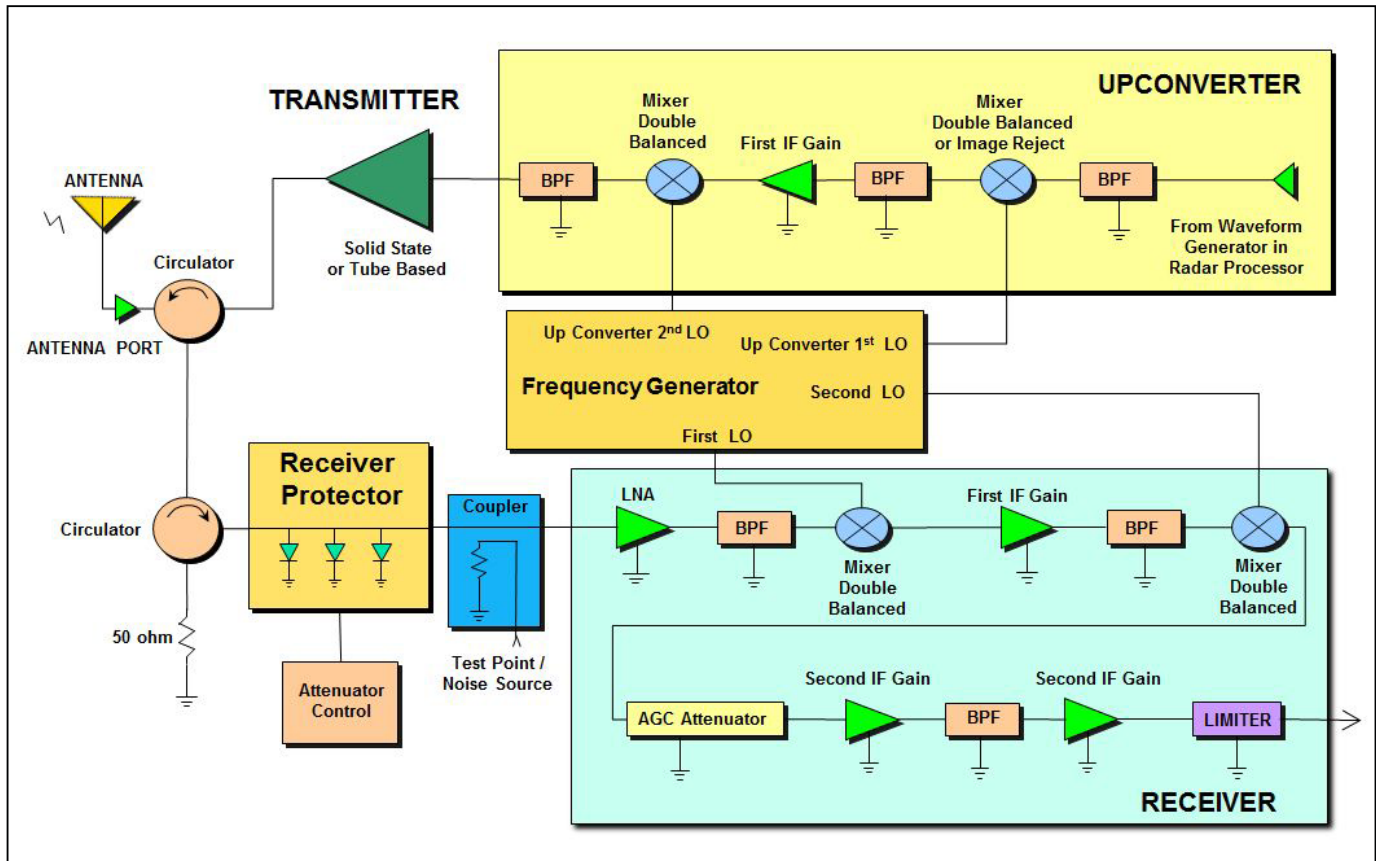

Ask us about integrating your designs today.